

# Dong Yang Servo Power Model Co.,Ltd

**MOTOR MODEL: BE2208-13(1400KV)**

**MOTOR OUTLINES (Weight: 44g)**

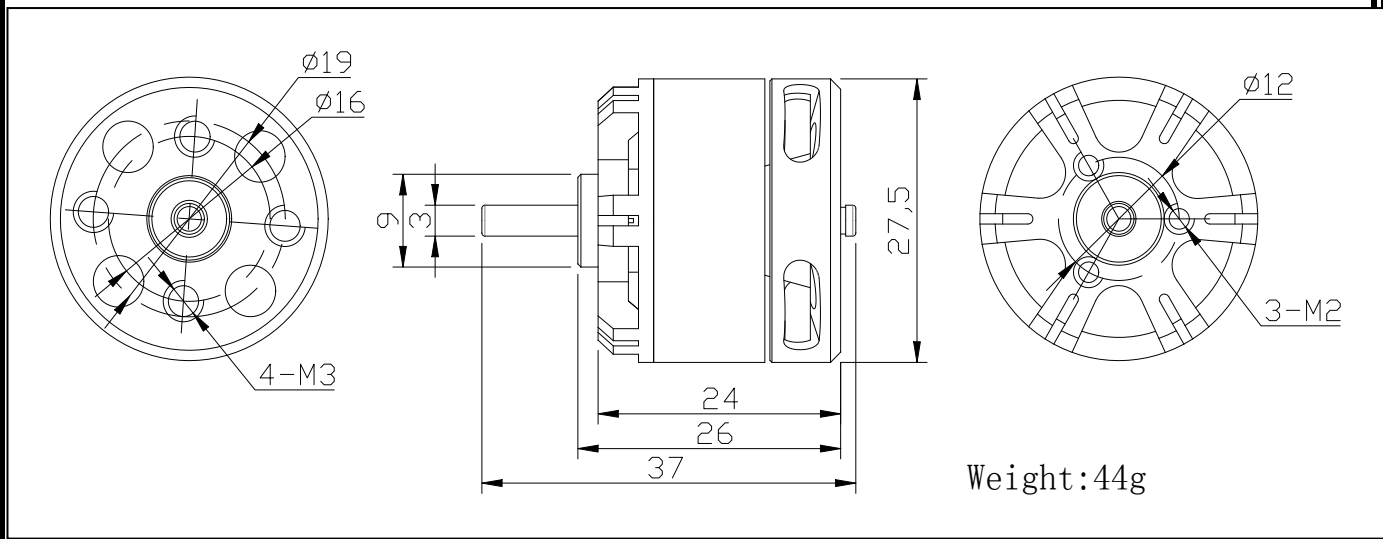

**MOTOR TECHNICAL DATA:**

VOLTAGE	NO LOAD		ON LOAD			LOAD TYPE
	CURRENT	SPEED	CURRENT	Pull	Power	
V	A	rpm	A	g	W	Battery/prop
7.4	0.4	7970	3.4	170	25.2	LiPo x 2/6x5E
			9.6	340	71.0	LiPo x 2/7x5E
			10.3	430	76.2	LiPo x 2/8x4E
			12.1	530	89.5	LiPo x 2/9x6E
11.1	0.5	11930	6.3	380	69.9	LiPo x 3/6x5E
			16.1	580	178.7	LiPo x 3/7x5E
			17.1	730	189.8	LiPo x 3/8x4E
			19	835	210.9	LiPo x 3/9x6E
14.8	0.5	15880	9.8	640	145.0	LiPo x 4/6x5E
			22.1	780	327.1	LiPo x 4/7x5E
			23.5	960	347.8	LiPo x 4/8x4E
			26	1060	384.8	LiPo x 4/9x6E

DYS final released BE series super strength out-runner high-end brushless motor, The BE series motor is with Kawasaki, Japan 1200 # 0.2mm high efficiency silicon steel and 40UH high temperature powerful magnet. Selected the Japanese NSK pure imported bearings to reduce motor vibration, shell using high-precision CNC machining and professional balancing test, making concentricity, balance is greatly enhanced. DYS BE Series high-end brushless motor perfectly compatible with more than 99% of commercially available brushless ESC.

- Low vibration motor great for flying
- To make aircraft more stable
  - Less operating noise
  - More efficient
  - Bearings long life