

Dong Yang Servo Power Model Co.,Ltd

MOTOR MODEL: BE2814-11 (700KV)

MOTOR OUTLINES (Weight: 100g)

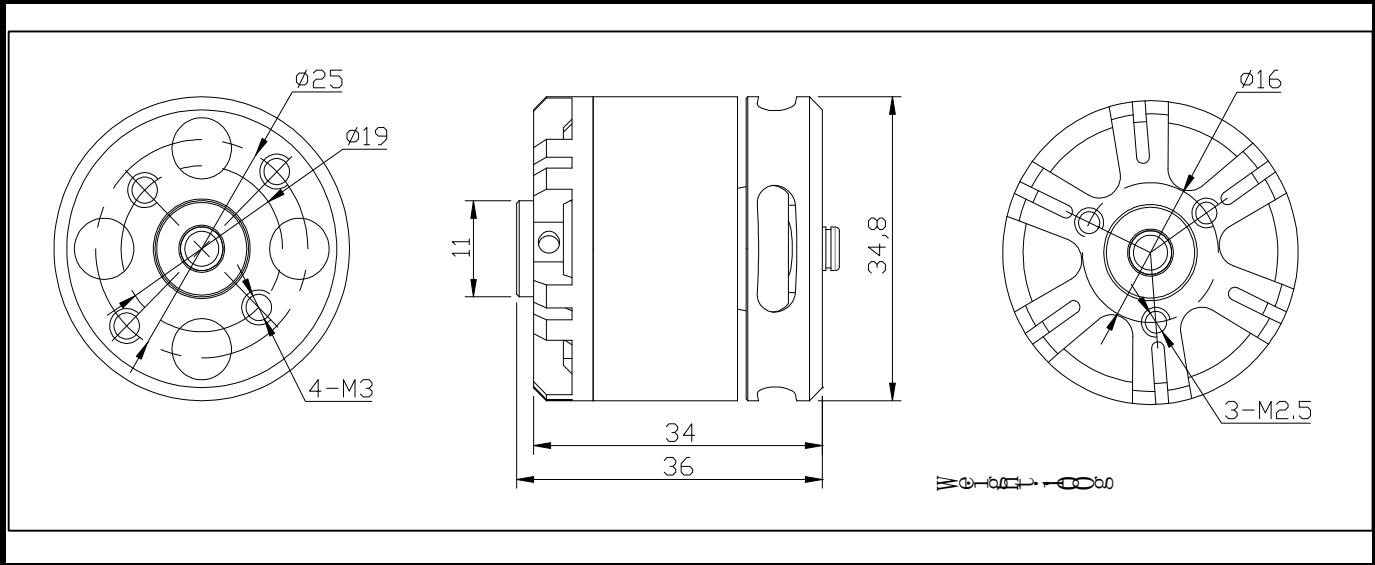

MOTOR TECHNICAL DATA:

VOLTAGE V	NO LOAD		ON LOAD			LOAD TYPE Battery/prop
	CURRENT A	SPEED rpm	CURRENT A	Pull g	Power W	
	11.1	0.7	7800	3.8	300	
14.8	0.8	10400	8.2	600	91.0	LiPo x 3/9x6 (APC)
			8.5	700	94.4	LiPo x 3/10x4.7 (APC)
			15.1	1120	167.6	LiPo x 3/12x3.8 (APC)
			6.1	530	90.3	LiPo x 4/8x4.5 (APC)
18.5	0.9	13000	13.1	1000	193.9	LiPo x 4/9x6 (APC)
			13.5	1160	199.8	LiPo x 4/10x4.7 (APC)
			23.2	1660	343.4	LiPo x 4/12x3.8 (APC)
22.2	0.9	15600	9	800	166.5	LiPo x 5/8x4.5 (APC)
			18.8	1420	347.8	LiPo x 5/9x6 (APC)
			19.2	1660	355.2	LiPo x 5/10x4.7 (APC)
			30.1	2060	556.9	LiPo x 5/10x4.7 (APC)
22.2	0.9	15600	11.2	1065	248.6	LiPo x 6/8x4.5 (APC)
			22	1710	488.4	LiPo x 6/9x6 (APC)
			22.6	1970	501.7	LiPo x 6/10x4.7 (APC)

DYS final released BE series super strength out-runner high-end brushless motor, The BE series motor is with Kawasaki, Japan 1200 # 0.2mm high efficiency silicon steel and 40UH high temperature powerful magnet. Selected the Japanese NSK pure imported bearings to reduce motor vibration, shell using high-precision CNC machining and professional balancing test, making concentricity, balance is greatly enhanced. DYS BE Series high-end brushless motor perfectly compatible with more than 99% of commercially available brushless ESC.

- Low vibration motor great for flying
- To make aircraft more stable
- Less operating noise
- More efficient
- Bearings long life



特佳电机制造厂

地址: 惠州市仲凯高新区平南工业区四大围村28号

电话: 0752-2090950

传真: 0752-2090951

样品检查记录表

客户名称: 兆荣

编号: 201103016

机种名	TF-13-2270/42+DV(绿盖)			温度	15℃		湿度			%			
批量	10PCS		抽检数	10PCS			检查日期	2011-3-21					
测试 项目	额定电压		DC3. V		额定负载			GCM					
	空载		起 动 电 压 V	起 动 电 流 A	起 动 转 矩 g. cm	旋 转 方 向	绝 缘 电 阻	噪 音	振 动	波 形	外 形 外 观	出 力 轴 长 mm	轴 向 间 隙 mm
规格	电 流 mA	转 速 rpm											
	序号						CW	≥10 (100V)	听 感	手 感	目 测	目 测	
1	289	18200		3.2		CW	OK	OK	OK	OK	OK	11.8	0.28
2	340	17900		3.1		CW	OK	OK	OK	OK	OK	11.9	0.2
3	223	16300		3		CW	OK	OK	OK	OK	OK	11.8	0.23
4	286	17400		3.25		CW	OK	OK	OK	OK	OK	12	0.3
5	321	17200		3.2		CW	OK	OK	OK	OK	OK	12.2	0.32
6	318	16700		3		CW	OK	OK	OK	OK	OK	12.1	0.3
7	222	16800		3.2		CW	OK	OK	OK	OK	OK	12.1	0.24
8	222	17900		3		CW	OK	OK	OK	OK	OK	12.4	0.2
9	227	17100		3		CW	OK	OK	OK	OK	OK	12.3	0.15
10	294	18000		3.2		CW	OK	OK	OK	OK	OK	11.9	0.2
11													
12													
13													
14													
15													
16													
17													
18													
19													
20													
X	274	173		3.115	DIV/0!							12.05	0.242
R	67	-15960		0.25	0							0.6	0.17
MAX	340	18200		3.25	0							12.4	0.32
MIN	222	16300		3	0							11.8	0.15
COPY:	客户		工程		检查	判定			OK		承认		